

Product Specification Datasheet

TNQ2CW6XL-CD203

100G QSFP28 CWDM4 Optical Transceiver



The 100G QSFP28 CWDM4 is a 4x25G single-mode fiber, hot pluggable optical transceiver with unique technology enables the integration of 4 transmitters, 4 receivers and an optical MUX/ DeMUX into a small form factor package that delivers a 100 Gbps data link in a compact QSFP28 footprint.

The optical connectivity is based on two Singlemode Fiber (SMF) LC connectors, one for Tx and one for Rx. The Tx and Rx each consist of 4 25GB/s CWDM channels, whose wavelengths are in the 1300nm range. The QSFP28 CWDM4 transceiver is designed for applications with a reach up to 2000m and with the use of FEC.

Features

- High density interconnectivity
- Supports 100Gb/s data rate links up to 2km on a Singlemode Fiber (SMF)
- Industry standard QSFP28 form factor
- Power Dissipation < 3.5W
- Single 3.3V Power Supply

Applications

- Data Center interconnections
- 100GBASE Ethernet links

General Description

- Compliant with the 100G CWDM4 MSA Technical Specification Rev 1.0
- Supports 100 Gbps data rates links from 2m to 2km over a standard SMF QSFP28 footprint (Quad Small Form-factor Pluggable) with 2 unidirectional LC SMF optical connector receptacles
- Compliant to the SFF-8665 Pluggable Transceiver Solution (QSFP28) MSA
- Electrical Interface based on CAUI-4 as defined by IEEE 802.3 CL83E
- Compliant to the SFF-8636 Common Management Interface MSA
- 38 pin hot pluggable edge connector electrical interface
- The transmitter consists of a retimed quad input, 4 un-cooled CWDM DFB lasers operating on the ITU G.694.2 wavelength grid at 1271, 1291, 1311 and 1331nm and multiplexed into a single SMF output
- The receiver consists of a CWDM de-multiplexer, a quad photodiode receiver and a retimed electrical output
- Provides Bias and Transmit Power Monitoring (TPM) for each of the 4 transmitter channels.
- Provides RSSI Monitoring for each of the 4 receiver channels.
- Provides monitoring of the voltage supplies and case temperature
- Provides Module Present and Interrupt signals
- Input control pins for Module Select, Module Reset and Low Power Modes
- Supports operation for a case temperature of 0° C to +70 ° C
- Includes customized coding option for module security implementation

Absolute Maximum Ratings

Parameter	Symbol	Min	Max	Units
Storage Temperature Range	T _{STG}	-40	+85	°C
Supply Voltage	V _{CC}	0	4	V
Relative Humidity	RH	10% to 90% non-condensing		

Operating Conditions

Parameter	Symbol	Min	Max	Units
Case Temperature- Operating	T _{CASE}	0	70	°C
Supply Voltage	V _{CC}	3.14	3.46	V
Power Consumption	P _{DISS}		3.5	W
Power Consumption- LP Mode	P _{DISS-LP}		1.5	W

Wavelength Lane Assignments

Transmitter Parameter	Lane	Min	Typical	Max	Units
Lane Wavelength Range	Lane 0	1264.5	1271	1277.5	nm
	Lane 1	1284.5	1291	1297.5	nm
	Lane 2	1304.5	1311	1317.5	nm
	Lane 3	1324.5	1331	1337.5	nm



Transmitter Optical Specifications

Transmitter Parameter	Lane	Min	Typical	Max	Units
Signaling rate, each lane		25.78125 ± 100ppm			Gb/s
Lane Wavelength Range	Lane 0	1264.5	1271	1277.5	nm
	Lane 1	1284.5	1291	1297.5	nm
	Lane 2	1304.5	1311	1317.5	nm
	Lane 3	1324.5	1331	1337.5	nm
Average Optical Power per lane		-6.5		2.5	dBm
Total Average Launch Power				8.5	dBm
Optical Modulation Amplitude (OMA), each lane		-4		2.5	dBm
Launch Power in OMA minus TDP, each lane		-5			dBm
Transmitter and Dispersion Penalty (TDP) each lane				3	dB
Average Launch Power per Lane @ TX Off State				-30	dBm
Extinction Ratio		3.5			dB
Relative Intensity Noise (OMA)				-130	dB/Hz
Side-Mode Suppression Ration (SMSR)		30			dB
Optical Return Loss Tolerance				20	dB
Transmitter Reflectance				-12	dB
Transmitter Output Power Monitoring Accuracy		-3		3	dB
Transmitter Eye Mask Definition {X1, X2, X3, Y1, Y2, Y3}		{0.31, 0.4, 0.45, 0.34, 0.38, 0.4}			



Receiver Optical Specifications

Receiver Parameter	Lane	Min	Typical	Max	Units
Signaling rate, each lane		25.78125 ± 100ppm			Gb/s
Lane Wavelength Range	Lane 0	1264.5	1271	1277.5	nm
	Lane 1	1284.5	1291	1297.5	nm
	Lane 2	1304.5	1311	1317.5	nm
	Lane 3	1324.5	1331	1337.5	nm
Damage Threshold		3.5			dBm
Average Receive Power, each lane		-11.5		2.5	dBm
Receiver Power, each lane (OMA)				2.5	dBm
Receiver Reflectance				-26.0	dB
Receiver Sensitivity (OMA) per lane at 5 x 10 ⁻⁵ BER				-10.0	dBm
RSSI Accuracy		-3.0		3.0	dB

QSFP28 Edge Connector and Pinout Description

The electrical interface to the transceiver is a 38 pins edge connector. The 38 pins provide high speed data, low speed monitoring and control signals, I2C communication, power and ground connectivity. The top and bottom views of the connector are provided below, as well as a table outlining the contact numbering, symbol and full description.

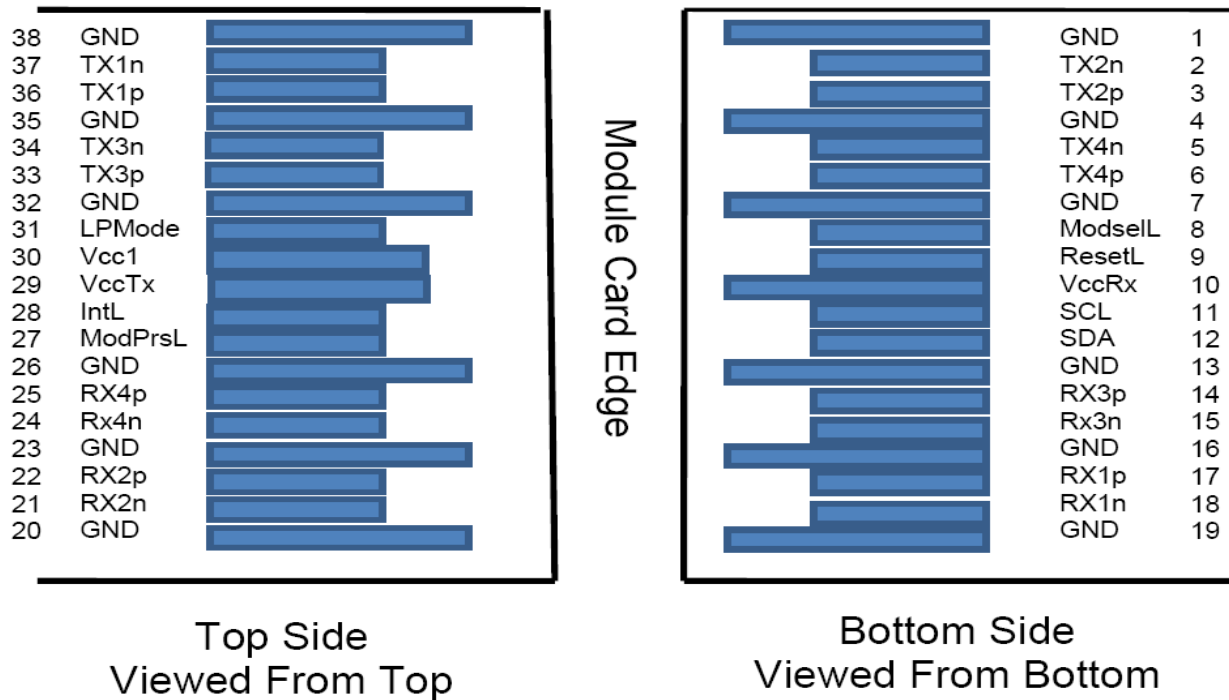

Figure 1. QSFP28 compliant 38-pin connector



QSFP Transceiver Pinout

Pin No.	Logic	Symbol	Description	Plug Sequence
1		GND	Ground	1
2	CML-I	TX2n	Transmitted Inverted Data Input	3
3	CML-I	TX2p	Transmitted Non-Inverted Data Input	3
4		GND	Ground	1
5	CML-I	TX4n	Transmitted Inverted Data Input	3
6	CML-I	TX4p	Transmitted Non-Inverted Data Input	3
7		GND	Ground	1
8	LVTTTL-I	ModSeil	Module Select	3
9	LVTTTL-I	ResetL	Module Reset	3
10		Vcc Rx	+3.3 VDC Receiver Power Supply	2
11	LVCMOS-I/O	SCL	Serial Clock for I2C Interface	3
12	LVCMOS-I/O	SDA	Serial Data for I2C Interface	3
13		GND	Ground	1
14	CML-O	RX3p	Receiver Non-Inverted Data Output	3
15	CML-O	RX3n	Receiver Inverted Data Output	3
16		GND	Ground	1
17	CML-O	RX1p	Receiver Non-Inverted Data Output	3
18	CML-O	RX1n	Receiver Inverted Data Output	3
19		GND	Ground	1
20		GND	Ground	1
21	CML-O	RX2n	Receiver Inverted Data Output	3
22	CML-O	RX2p	Receiver Non-Inverted Data Output	3
23		GND	Ground	1
24	CML-O	RX4n	Receiver Inverted Data Output	3
25	CML-O	RX4p	Receiver Non-Inverted Data Output	3
26		GND	Ground	1
27	LVTTTL-O	ModPrsL	Module Present	3
28	LVTTTL-O	IntL	Interrupt	3
29		Vcc Tx	+3.3 VDC Transmitter Power Supply	2
30		Vcc1	+3.3 VDC Power Supply	2
31	LVTTTL-I	LPMODE	Low Power Mode	3
32		GND	Ground	1
33	CML-I	TX3p	Transmitted Non-Inverted Data Input	3
34	CML-I	TX3n	Transmitted Inverted Data Input	3
35		GND	Ground	1
36	CML-I	TX1p	Transmitted Non-Inverted Data Input	3
37	CML-I	TX1n	Transmitted Inverted Data Input	3
38		GND	Ground	1

Functional Block Diagram

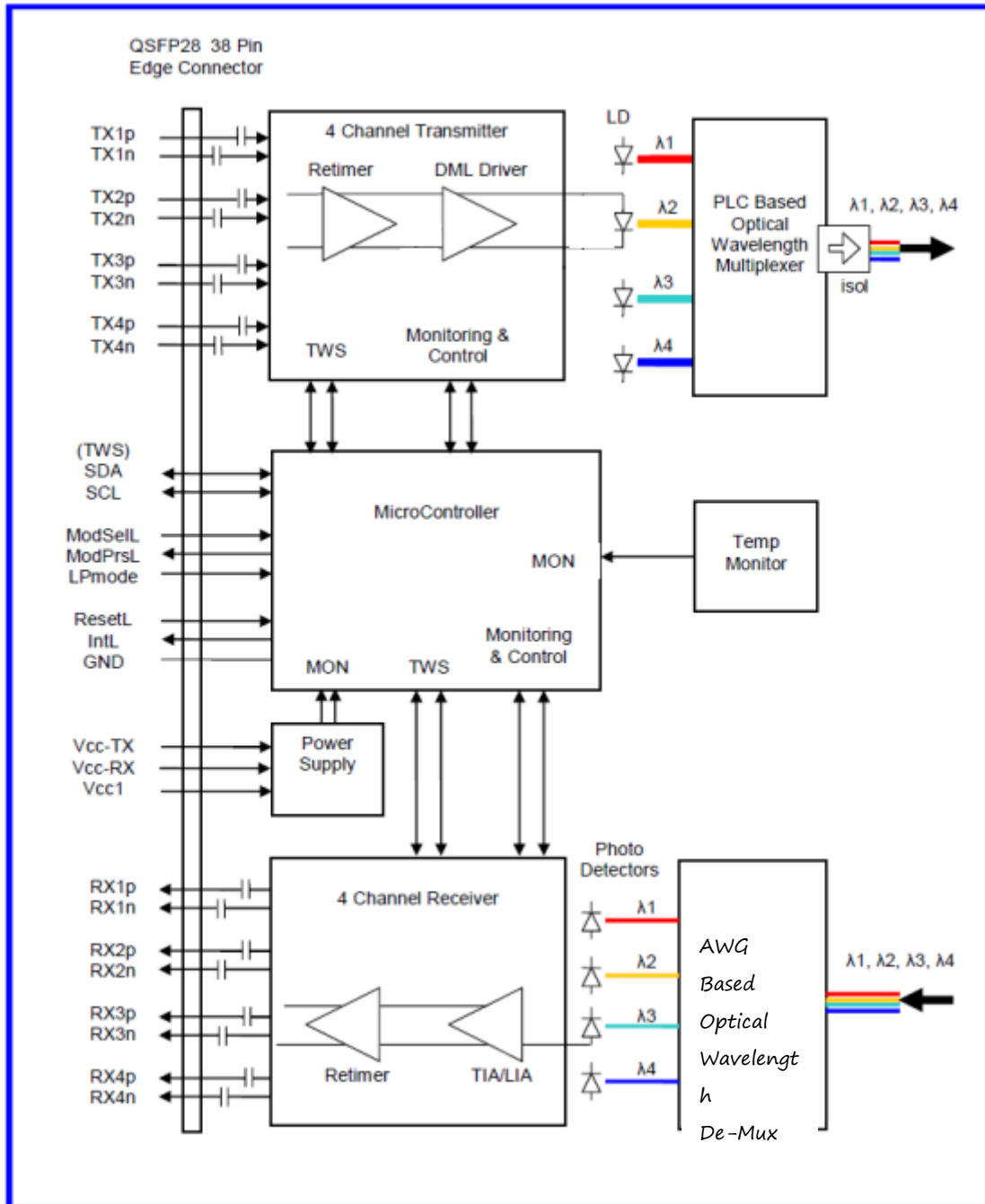

Figure 2. Functional Block Diagram

Mechanical Drawings

Unit:mm

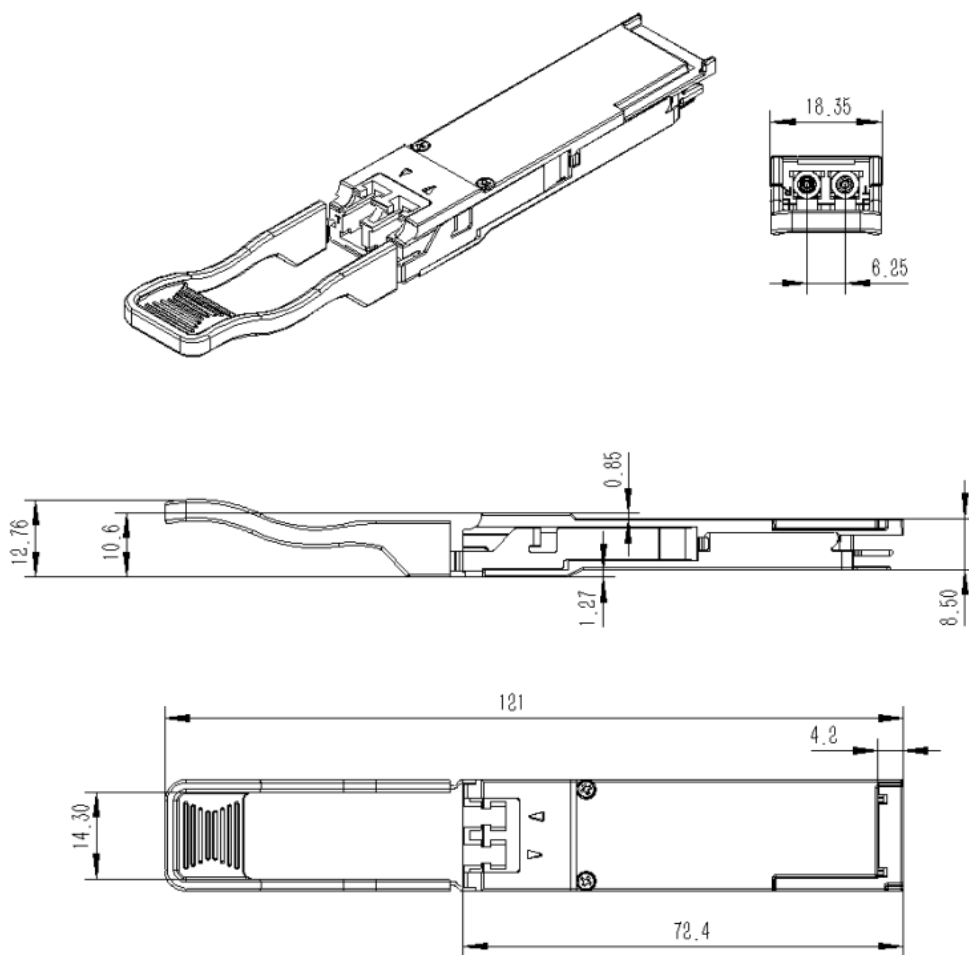

Figure 3. Mechanical Dimensions

Order information

Part Number	Description
TNQ2CW6XL-CD203	QSFP28 100G CWDM4 Optical Transceiver